

IPtHA Spring Fling

In Hand and W/T Trail (Classes 1-10)

Show Date: 05-02-2025

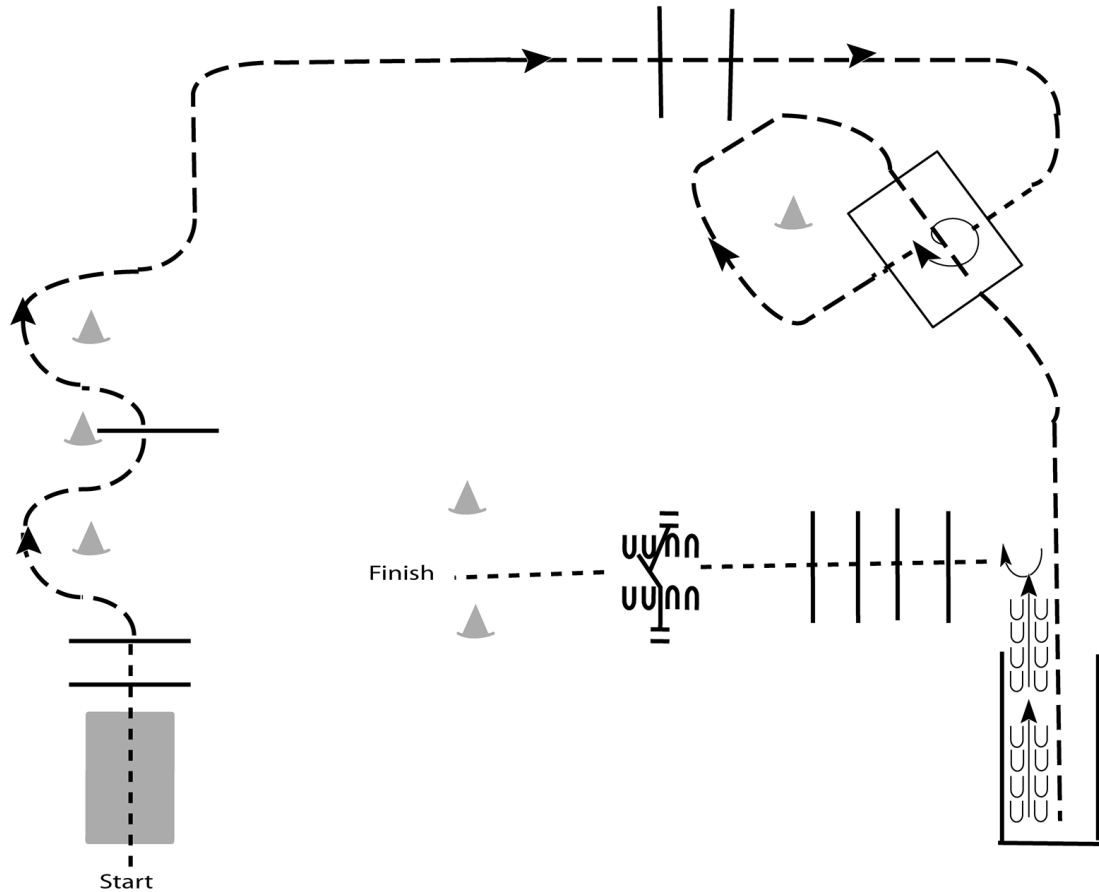

1. Walk over bridge and over poles.
2. Jog through serpentine and over pole.
3. Continue to jog over poles.
4. Break to a walk and walk into box. Turn a full turn to the right and walk out of box.
5. Jog through box and into chute
6. Back out of chute
7. Turn 90 degrees and walk over poles to gate
8. Work gate and walk to finish

Walk	-----
Jog	-----
Extended Jog	-----
Lope	—————
Leg Yield	
Lead Change	—/—
Back	←←←←←
Marker	Ⓚ
Sidepass	←-----→

[T/1-6]

Pattern Provided by:

IPtHA

IPtHA Spring Fling

ABO and Novice Trail (Classes 11-14)

Show Date: 05-02-2025

www.HorseShowPatterns.com

www.HorseShowPatterns.com

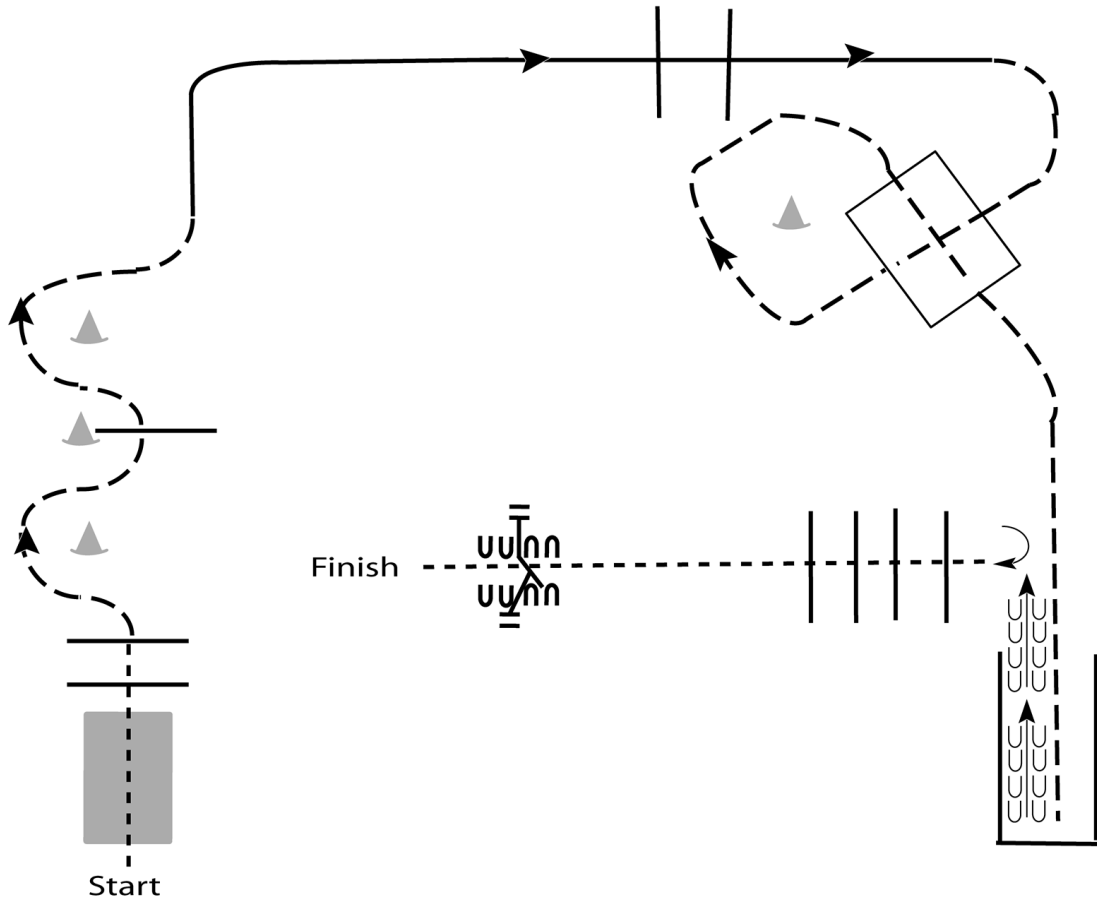

Be ready at start.

1. Walk over bridge and over poles.
2. Jog through serpentine and over pole.
3. Lope on the right lead over poles.
4. Jog through box and into chute.
5. Back out of chute.
6. Turn 90 degrees and walk over elevated poles.
7. Work gate with left hand.

Walk	-----
Jog	- - - - -
Extended Jog	- - - - -
Lope	—————
Leg Yield	
Lead Change	— / —
Back	← ← ← ← ←
Marker	Ⓚ
Sidepass	← ——— →

[T/1-6]

Pattern Provided by:

IPtHA

IPtHA Spring Fling

YA, AM, Open Trail (Classes 15-21)

Show Date: 05-02-2025

www.HorseShowPatterns.com

www.HorseShowPatterns.com

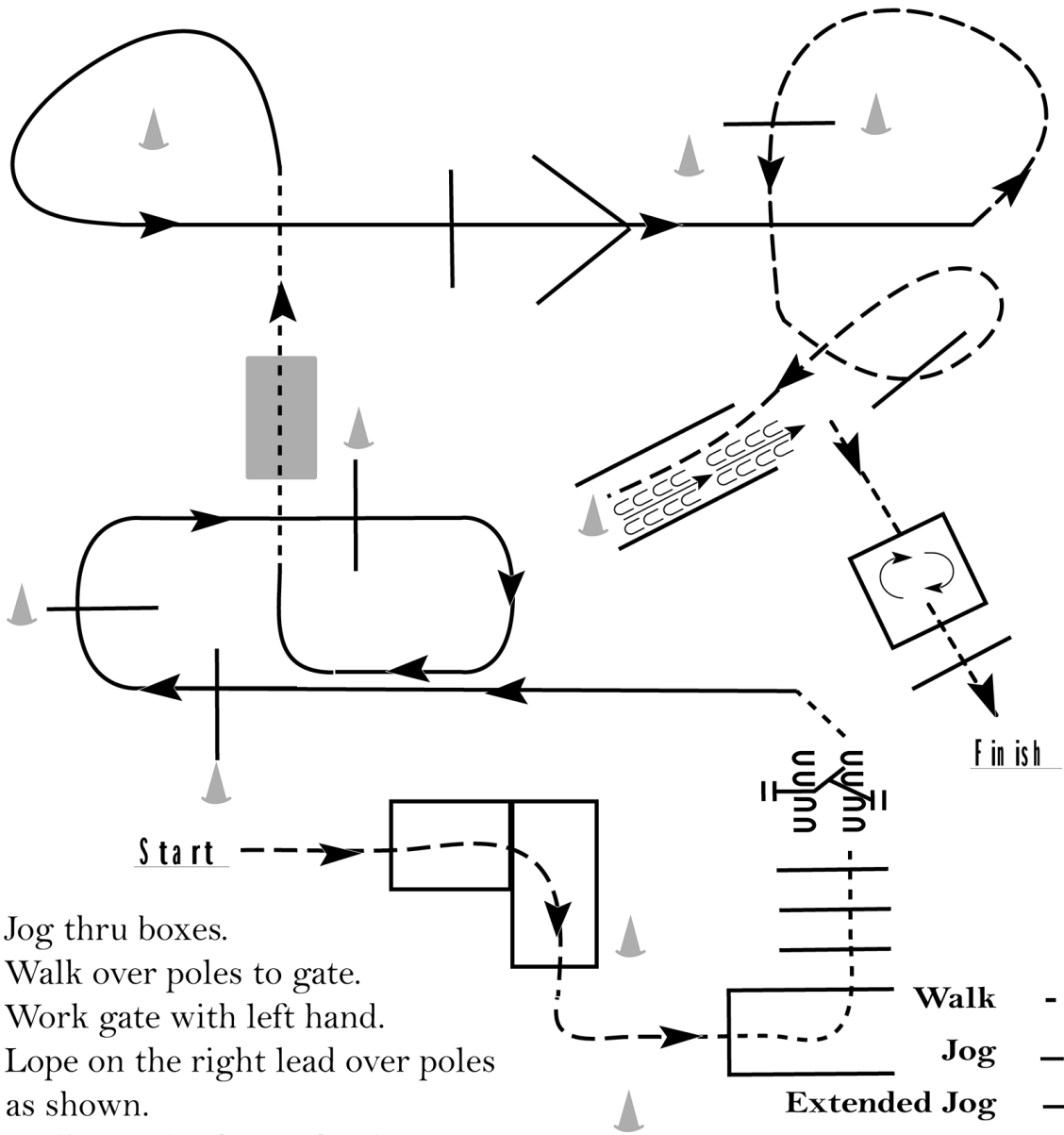

1. Jog thru boxes.
2. Walk over poles to gate.
3. Work gate with left hand.
4. Lope on the right lead over poles as shown.
5. Walk over bridge and pole.
6. Lope on the left lead over poles.
7. Jog over 2 poles and into chute.
8. Back thru chute and walk into box.
9. Turn 360 degrees to the right in box and walk out over pole to finish.

Walk	-----
Jog	- - - - -
Extended Jog	- - - - -
Lope	—————
Leg Yield	
Lead Change	↘
Back	←←←←←
Marker	(B)
Sidepass	←-----→

[T/2-24]

Pattern Provided by:
IPtHA

IPtHA Spring Fling

Ranch Trail (Classes 22-27)

Show Date: 05-02-2025

www.HorseShowPatterns.com

www.HorseShowPatterns.com

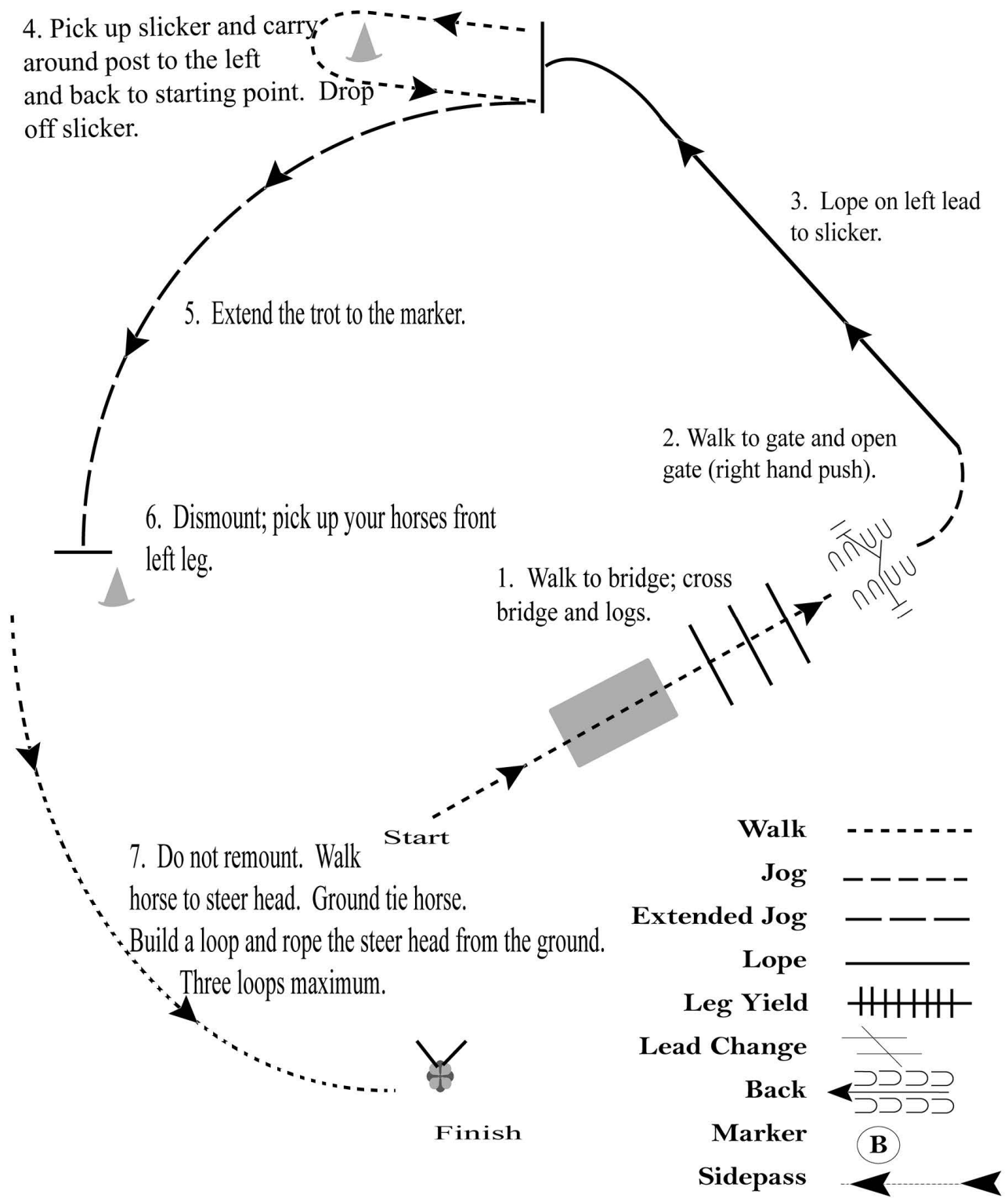

[RT/3]

Pattern Provided by:
IPtHA

IPtHA Spring Fling

Western Riding (Classes 29-30)

Show Date: 05-02-2025

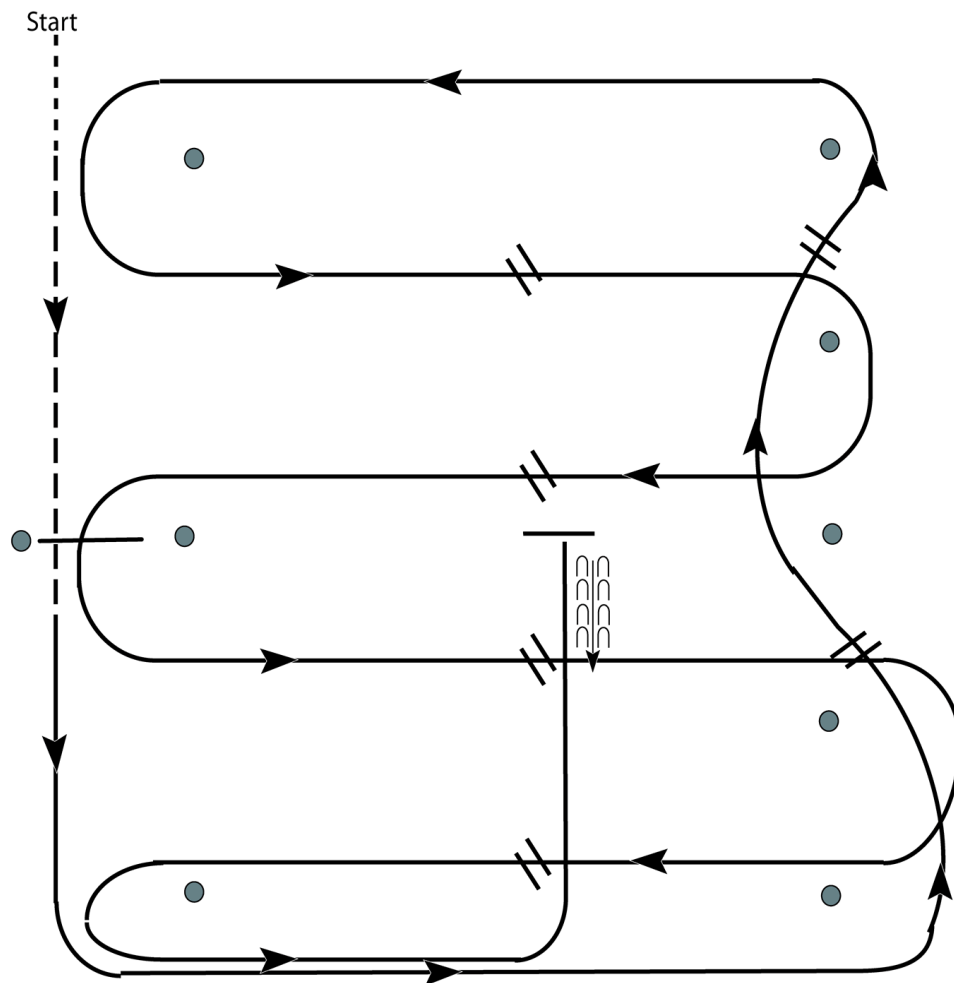

1. Walk at least 15' & jog over log.
2. Transition to left lead and lope around end.
3. First line change.
4. Second line change. Lope around end of arena
5. First crossing change.
6. Second crossing change.
7. Lope over log.
8. Third crossing change.
9. Fourth crossing change.
10. Lope up the center, stop and back.

[WR/GP-1]

Pattern Provided by:

IPtHA

IPtHA Spring Fling

Ranch Riding (Classes 41-47)

Show Date: 05-02-2025

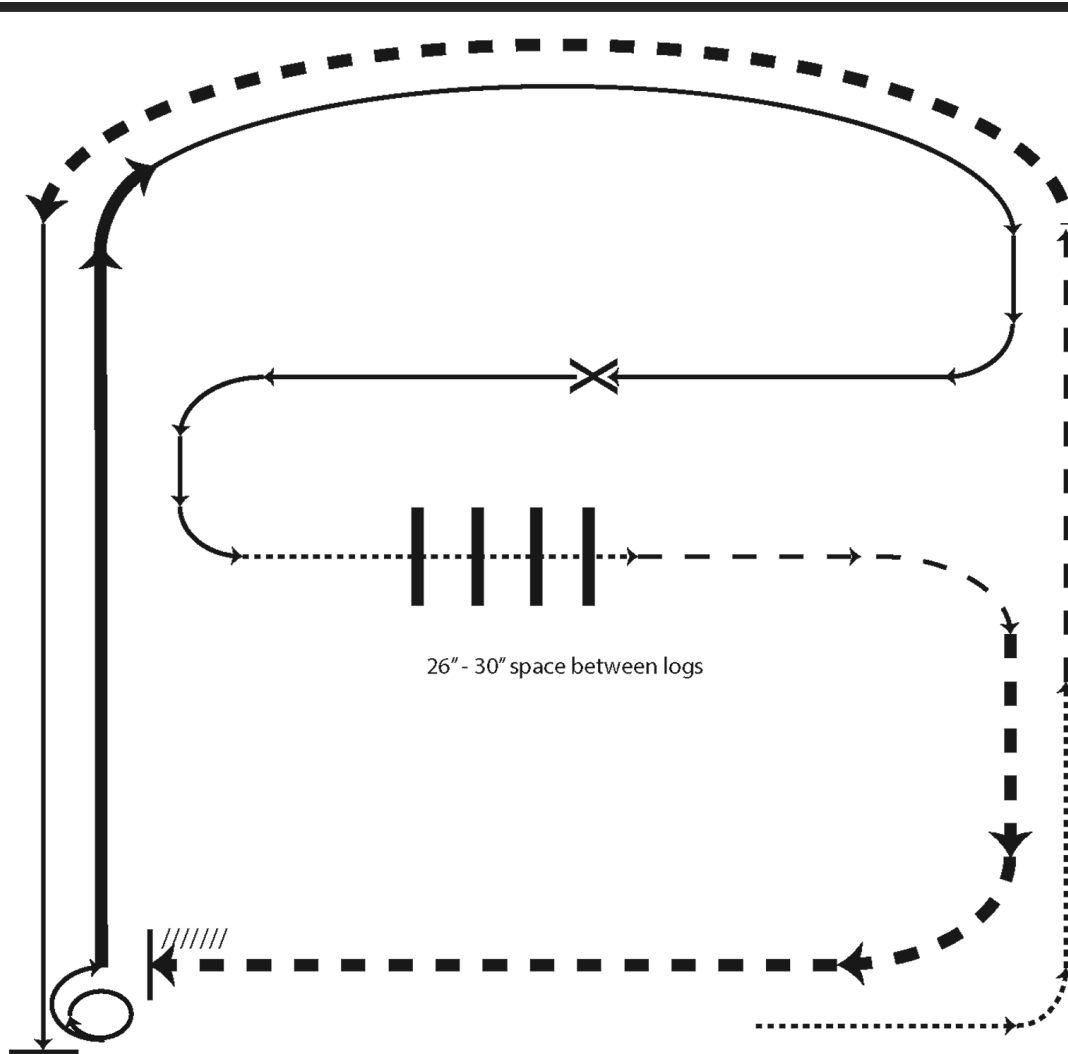

26" - 30" space between logs

- X Lead Change
- Walk
- - - Trot
- - - Ext Trot
- — — Lope
- — — Ext Lope
- /////// Back

1. Walk
2. Trot
3. Extended trot
4. Left lead lope
5. Stop, 1 1/2 turn right
6. Extended lope
7. Collect to working lope-right lead
8. Change leads (simple or flying)
9. Walk
10. Walk over logs
11. Trot
12. Extended trot
13. Stop and back

[RR/AQHA-2]

Pattern Provided by:

IPtHA

IPtHA Spring Fling

W/T Ranch Riding (Classes 48-49)

Show Date: 05-02-2025

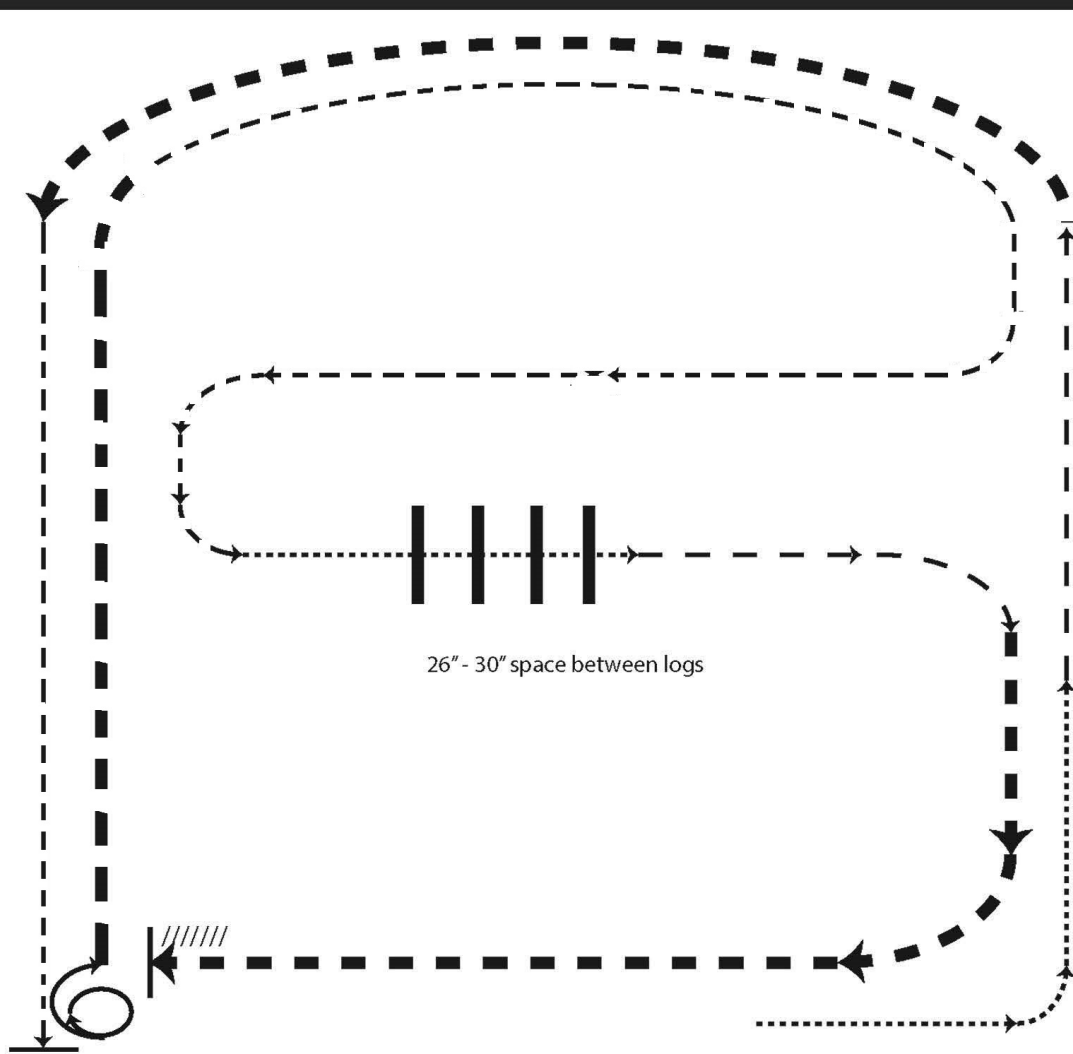

- X Lead Change
- Walk
- - - Trot
- - - Ext Trot
- — — Lope
- — — Ext Lope
- /////// Back

1. Walk
2. Trot
3. Extended trot
4. Trot
5. Stop, 1 1/2 turn right
6. Extended Trot
7. Collect to Trot
8. Walk
9. Walk over Logs
10. Trot
11. Extended Trot
12. Stop and Back

[RR/AQHA-2]

Pattern Provided by:

IPtHA

IPtHA Spring Fling

Ranch Horsemanship (Classes 50-53)

Show Date: 05-02-2025

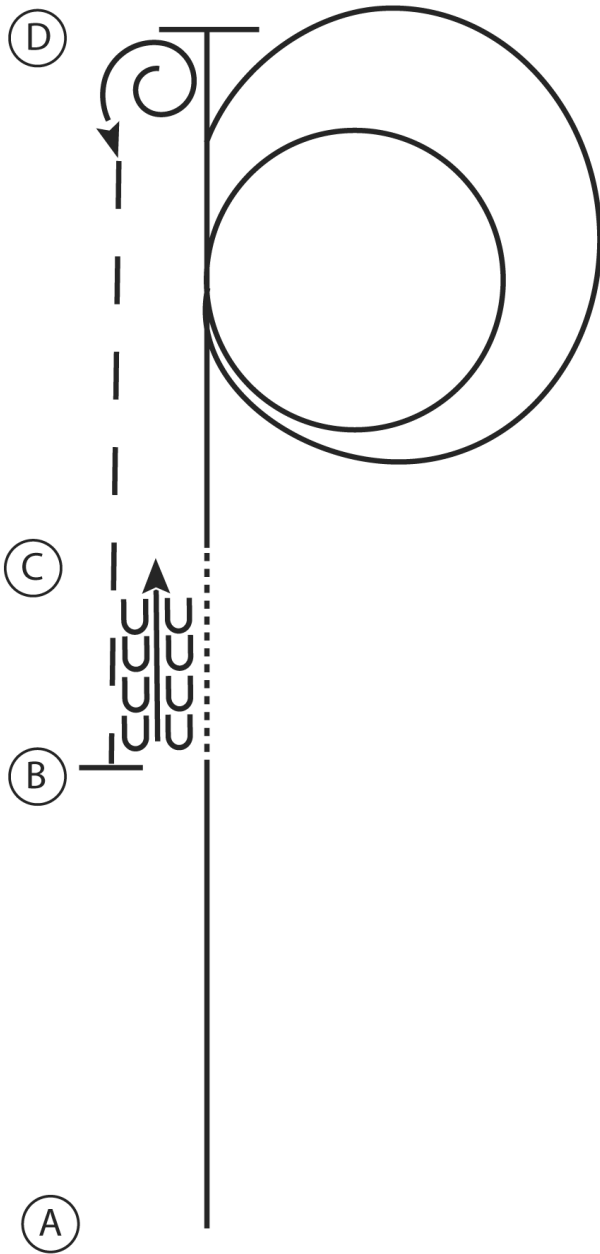

1. Lope A to B on the left lead
2. Walk B to C
3. At C lope on the right lead towards D
4. Before D lope a large fast circle to the right followed by a small slow circle to the right and continue to D
5. At D stop and perform a 540 degree turn to the left
6. Extend the jog to B
7. At B stop and back to C

Walk
Jog	-----
Extended Jog	-----
Lope	—————
Leg Yield	
Lead Change	↘
Back	←←←←←
Marker	Ⓚ
Sidepass	←←←←←

[WH/3-10]

Pattern Provided by:

IPtHA

IPtHA Spring Fling

ABO Western Horsemanship (Classes 115-116)

Show Date: 05-02-2025

w w w . H o r s e S h o w P a t t e r n s . c o m

w w w . H o r s e S h o w P a t t e r n s . c o m

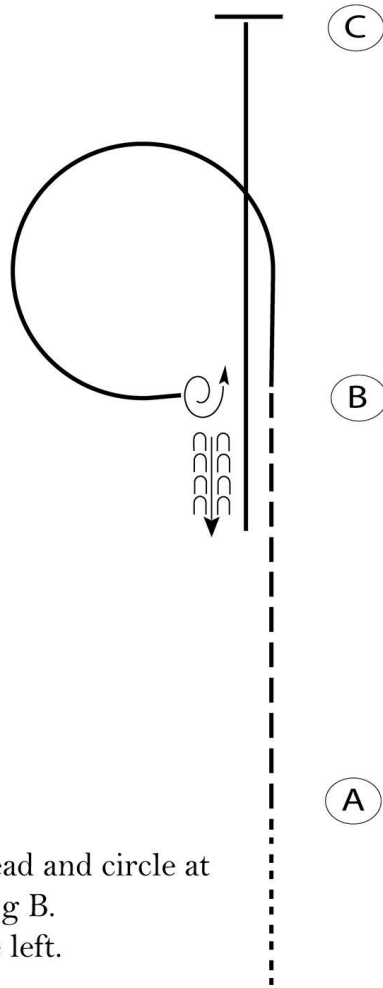

Begin before A at a Walk

1. Jog from A to B.
2. At B, lope on the left lead and circle at B as shown. Stop facing B.
3. Turn 1 1/4 turn to the left.
4. Back one horse length.
5. Lope on the right lead to C. Stop at C.

Follow the instructions of your ring steward.

Walk	-----
Jog	- - - - -
Extended Jog	- - - - -
Lope	—————
Leg Yield	
Lead Change	— / —
Back	← C C C C C
Marker	Ⓚ
Sidepass	←-----→

[WH/2-17]

Pattern Provided by:

IPtHA

IPtHA Spring Fling

W/T Western Horsemanship (Classes 117-120)

Show Date: 05-02-2025

www.HorseShowPatterns.com

www.HorseShowPatterns.com

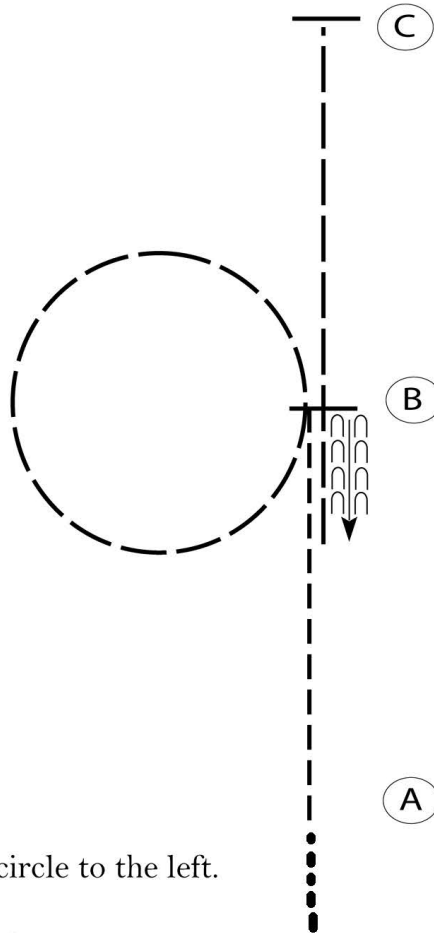

Start with Walk to A.

1. Jog from A to B.
2. Extend the jog in a circle to the left.
3. Stop at B.
4. Back one horse length at B.
5. Jog to C.
6. Stop at C.

Follow the instructions of your ring steward.

Walk	-----
Jog	- - - - -
Extended Jog	- - - - -
Lope	—————
Leg Yield	
Lead Change	— / —
Back	← — — — — — — — — —
Marker	Ⓚ
Sidepass	← — — — — →

[WH/WT-18]

Pattern Provided by:

IPtHA

IPtHA Spring Fling

Nov and YA Western Horsemanship (Classes 121-125)

Show Date: 05-02-2025

w w w . H o r s e S h o w P a t t e r n s . c o m

w w w . H o r s e S h o w P a t t e r n s . c o m

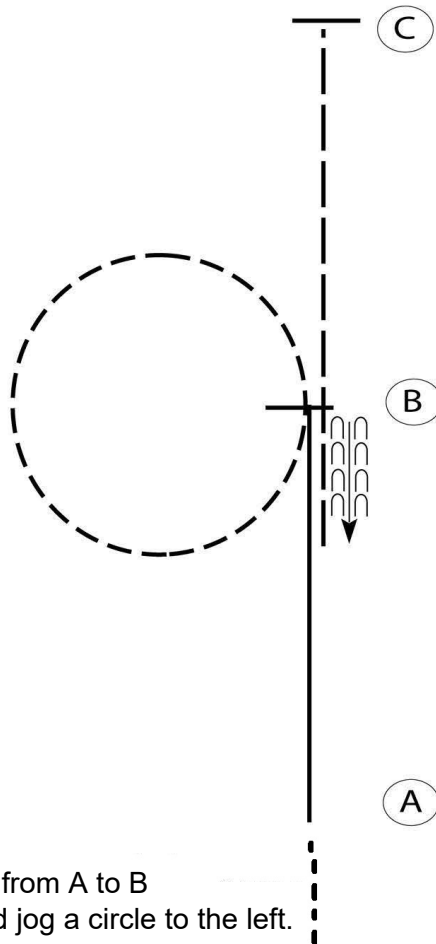

1. Walk to A
2. Lope on the right lead from A to B
3. Break to a jog at B and jog a circle to the left.
4. Stop at B
5. Back one horse length at B
6. Extend the jog to C
7. Stop at C.

Follow the instructions of your ring steward.

Walk	-----
Jog	- - - - -
Extended Jog	- - - - -
Lope	—————
Leg Yield	
Lead Change	— / —
Back	← C C C C C
Marker	Ⓚ
Sidepass	←-----→

[WH/2-18]

Pattern Provided by:

IPtHA

IPtHA Spring Fling

Am Western Horsemanship (Classes 126-128)

Show Date: 05-02-2025

www.HorseShowPatterns.com

www.HorseShowPatterns.com

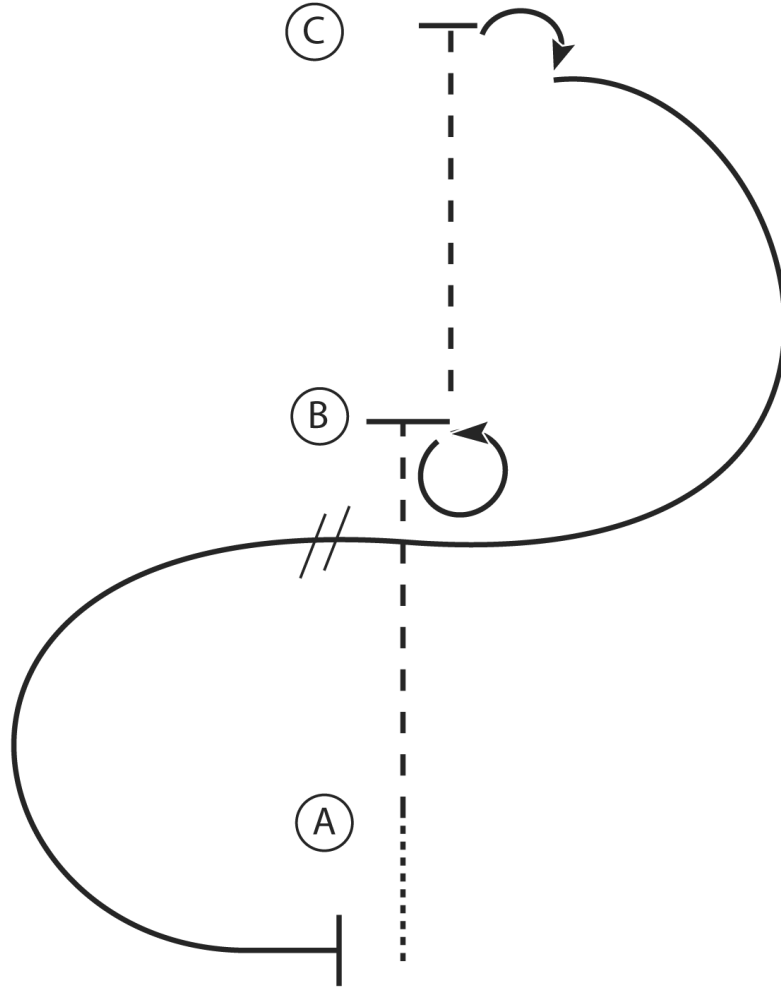

1. Walk to A
2. Jog A to B
3. Stop at B and perform a 360 degree turn to the left
4. Jog B to C
5. Stop at C and perform a 90 degree turn to the right
6. Lope a half circle to B on the right lead
7. At B perform a lead change and lope a half circle to A on the left lead
8. Stop at A

Walk
Jog	-----
Extended Jog	-----
Lope	—————
Leg Yield	
Lead Change	↘
Back	←←←←←
Marker	(B)
Sidepass	←←←←←

[WH/2-30]

Pattern Provided by:

IPtHA

IPtHA Spring Fling

ABO and Nov Showmanship (Classes 136 - 137 and 144-145)

Show Date: 05-02-2025

w w w . H o r s e S h o w P a t t e r n s . c o m

w w w . H o r s e S h o w P a t t e r n s . c o m

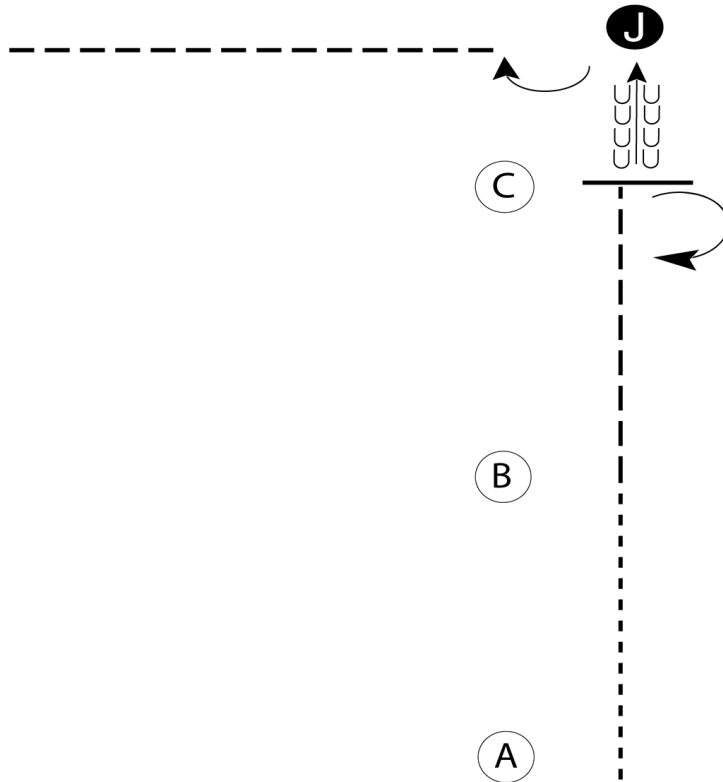

1. Walk from A to B.
2. Trot from B to C.
3. Stop at C and perform a 180 degree turn.
4. Back to Judge, set up for inspection.
5. When dismissed perform a 90 degree turn and trot straight away from Judge.

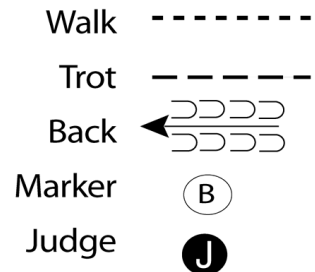

[S/2-6]

Pattern Provided by:

IPtHA

IPtHA Spring Fling

W/T Showmanship (Classes 138-141)

Show Date: 05-02-2025

w w w . H o r s e S h o w P a t t e r n s . c o m

w w w . H o r s e S h o w P a t t e r n s . c o m

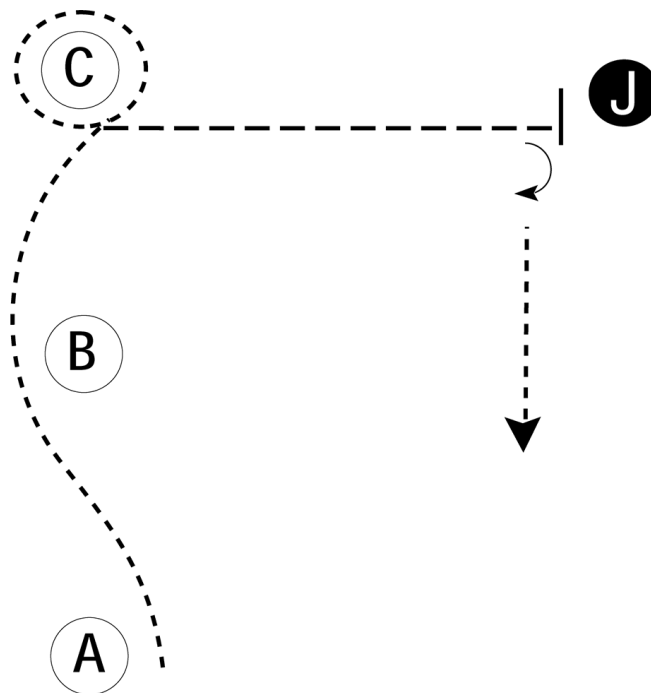

Be ready at A.

1. When acknowledged, walk from A, around B and to C.
2. Walk a tight circle around C.
3. Trot to judge.
4. Stop and set up for inspection.
5. When dismissed, perform a 90 degree turn and walk away from judge.

Follow the directions of your ring steward.

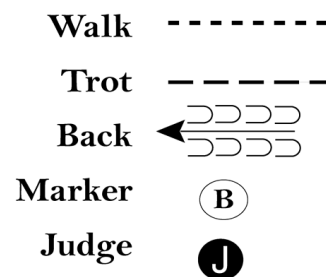

[S/WT-58]

Pattern Provided by:

IPtHA

IPtHA Spring Fling

Am W/T Showmanship (walk only) (Classes 142-143)

Show Date: 05-02-2025

w w w . H o r s e S h o w P a t t e r n s . c o m

w w w . H o r s e S h o w P a t t e r n s . c o m

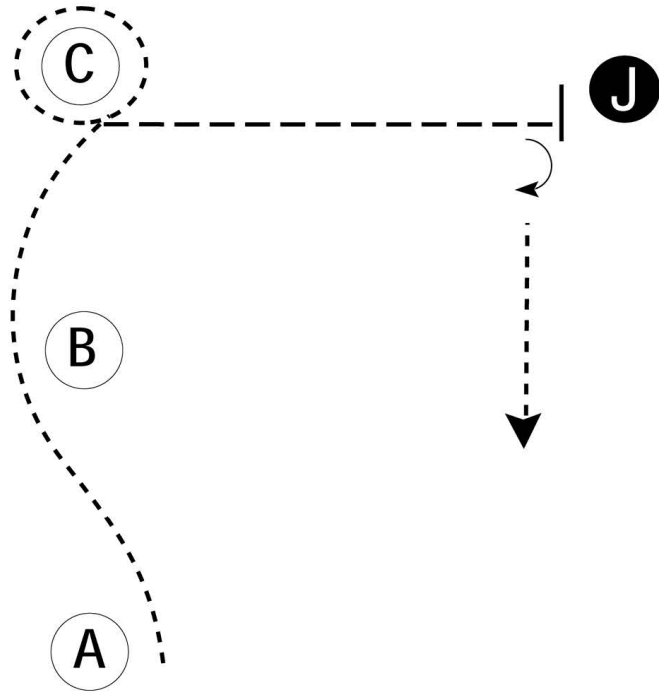

Be ready at A.

1. When acknowledged, walk from A, around B and to C.
2. Walk a tight circle around C.
3. Walk to judge.
4. Stop and set up for inspection.
5. When dismissed, perform a 90 degree turn and walk away from judge.

Follow the directions of your ring steward.

Walk	-----
Trot	- - - - -
Back	← ⊃ ⊃ ⊃
Marker	⊙ B
Judge	⊙ J

[S/WT-58]

Pattern Provided by:
IPtHA

IPtHA Spring Fling

YA and Am Showmanship (Classes 146-151)



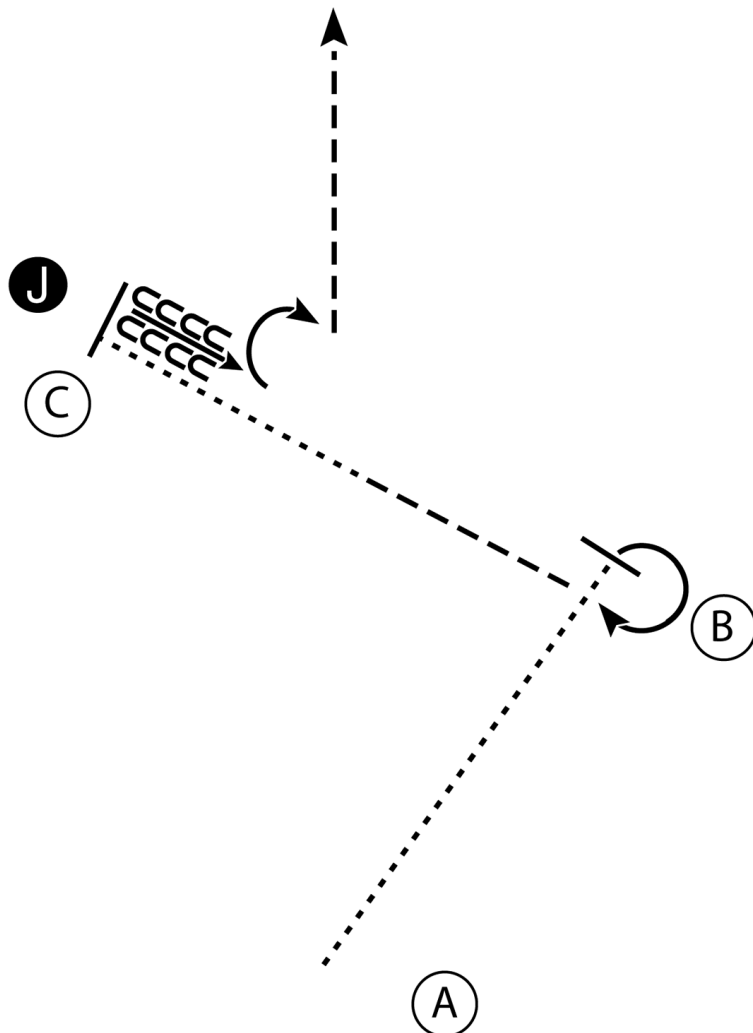

Show Date: 05-02-2025

www.HorseShowPatterns.com

www.HorseShowPatterns.com



1. Walk from A to B.
2. Stop and perform a 270 degree turn.
3. Trot half way to C, break to walk and walk to C.
4. Stop and set up for inspection.
5. When dismissed back four steps.
6. Perform a 90 degree turn and trot to line-up.

- Walk 
- Trot 
- Back 
- Marker 
- Judge 

[S/2-13]

Pattern Provided by:

IPtHA

IPtHA Spring Fling

English Showmanship (Classes 152-153)

Show Date: 05-02-2025

w w w . H o r s e S h o w P a t t e r n s . c o m

w w w . H o r s e S h o w P a t t e r n s . c o m

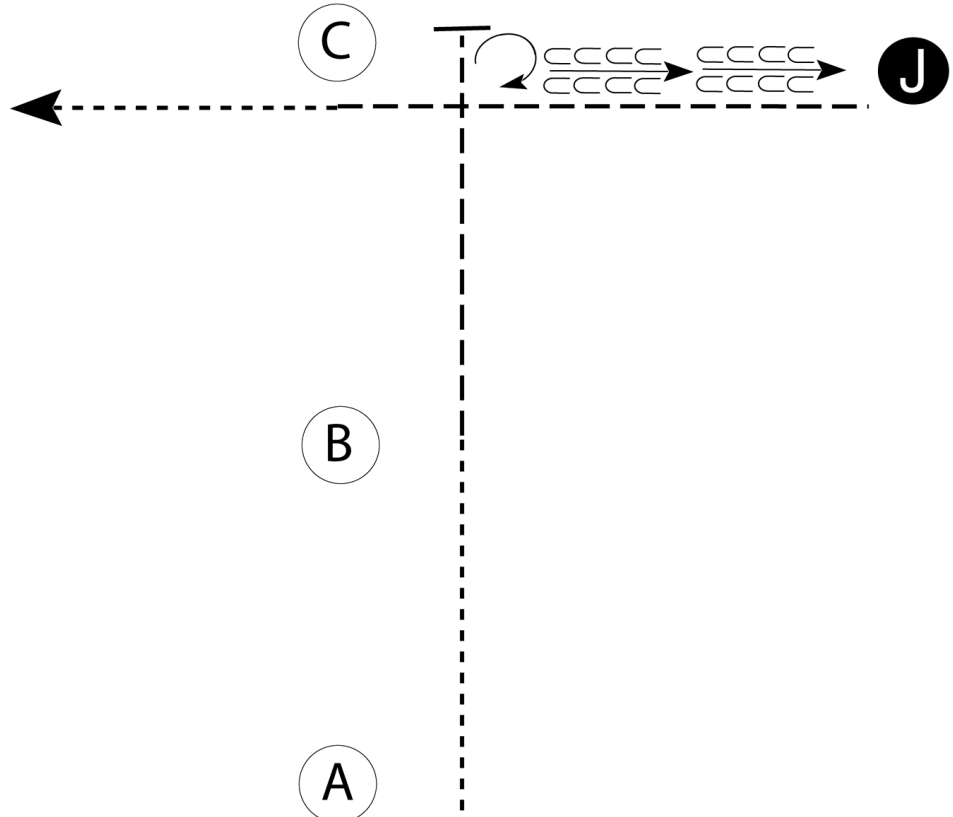

Be ready at A.

1. Walk to B.
2. Trot to C.
3. Stop and perform a 270 degree turn.
4. Back approximately one horse length.
5. Stop and set up for inspection.
6. When dismissed, trot to C.
7. Break to a walk when even with C and walk straight away.

Follow the instructions of your ring steward.

Walk	-----
Trot	- - - - -
Back	←
Marker	ⓑ
Judge	ⓐ

[S/2-44]

Pattern Provided by:

IPtHA

IPtHA Spring Fling

ABO and Nov English Equitation (Classes 178-179 and Classes 184-185)

Show Date: 05-02-2025

w w w . H o r s e S h o w P a t t e r n s . c o m

w w w . H o r s e S h o w P a t t e r n s . c o m

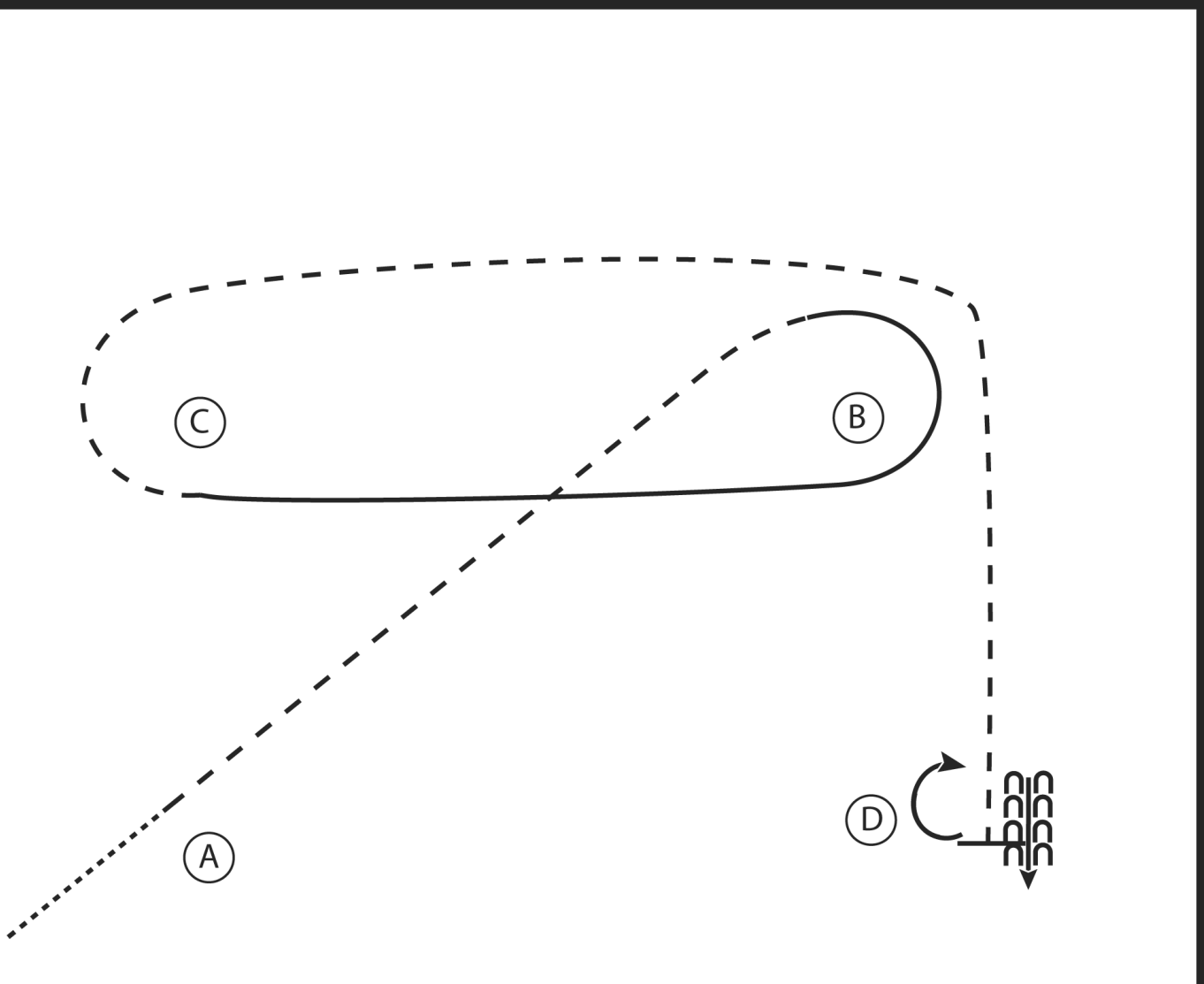

1. Walk to A
2. Sitting trot to B
3. At B canter on the right lead around B to C
4. At C posting trot around C and B to D
5. At D stop and perform a 180 degree turn to the right on the hindquarters
6. Back 4 steps

Walk
Trot	-----
Extended Trot	-----
Canter	—————
Leg Yield	
Lead Change	↘
Back	←←←←
Marker	(B)
Sidepass	←←←←

[HSE/2-10]

Pattern Provided by:

IPtHA

IPtHA Spring Fling

W/T Equitation (Classes 180-183)

Show Date: 05-02-2025

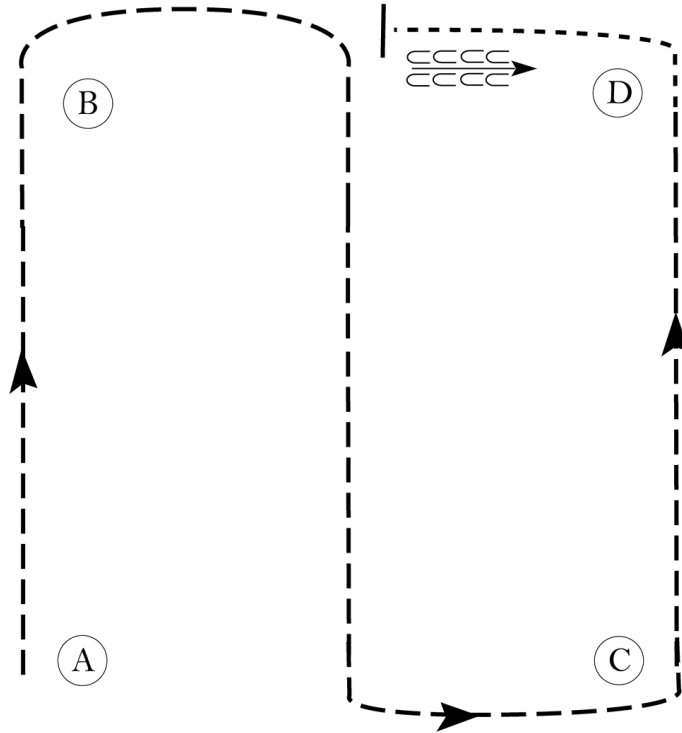

Be ready at A.

1. Posting trot to and around B on the left diagonal.
2. Halfway between B and C, change diagonals.
3. Posting trot on the right diagonal to and around C.
4. Continue to trot to D.
5. At D, walk.
6. Walk until halfway to B, stop and back one horse length.

Walk	-----
Trot	- - - - -
Extended Trot	— — — —
Canter	—————
Leg Yield	
Lead Change	— / —
Back	← ← ← ← ←
Marker	⊙ B
Sidepass	← — — — ←
Hand Gallop	— — — —

[HSE/WT-25]

Pattern Provided by:

IPtHA

w w w . H o r s e S h o w P a t t e r n s . c o m

w w w . H o r s e S h o w P a t t e r n s . c o m

IPtHA Spring Fling

Ya and Am English Equitation (Classes 186-190)

Show Date: 05-02-2025

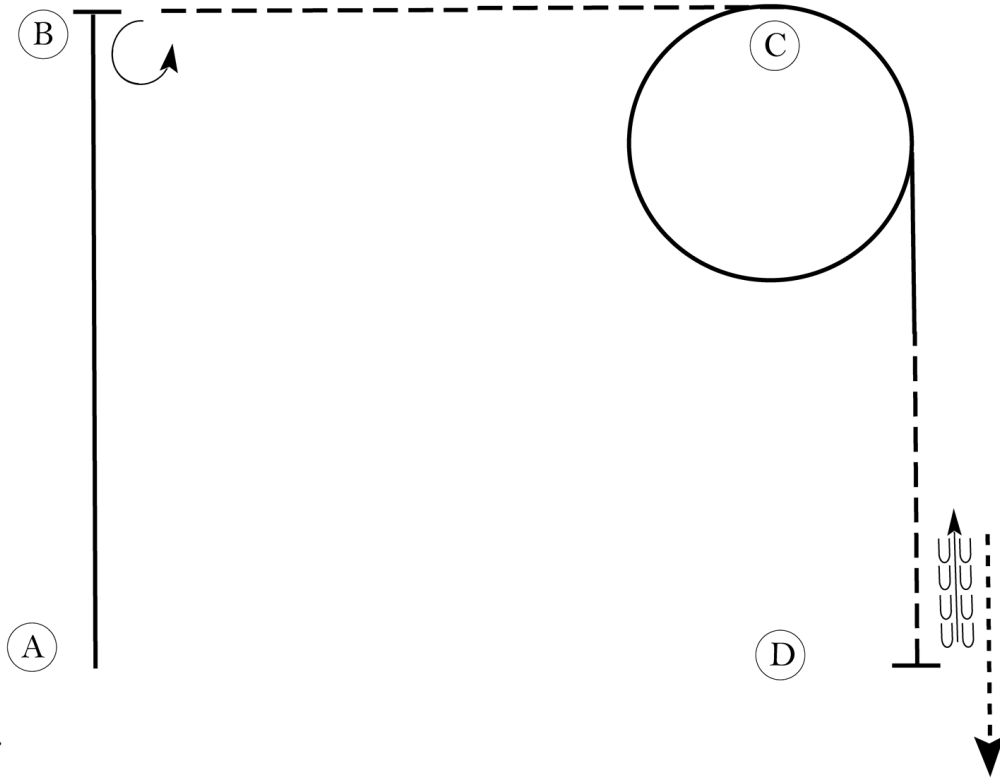

Be ready at A.

1. Canter on the left lead to B.
2. Stop at B and execute a 270 degree turn on the haunches to the left.
3. Posting trot on the right diagonal to C.
4. Canter on the right lead in a circle around C.
5. Continue on the right lead halfway to D.
6. Posting trot on the left diagonal to D.
7. Stop at D and back approximately one horse length.
8. Walk forward to and past D.

Follow the instructions of your ring steward.

Walk	-----
Trot	- - - - -
Extended Trot	-----
Canter	-----
Leg Yield	
Lead Change	///
Back	←←←
Marker	(B)
Sidepass	←-----→
Hand Gallop	-----

[HSE/2-43]

Pattern Provided by:

IPtHA